

IF  
IN DOUBT,  
ASK

NOTE: NOT FOR CONSTRUCTION UNLESS CERTIFIED.

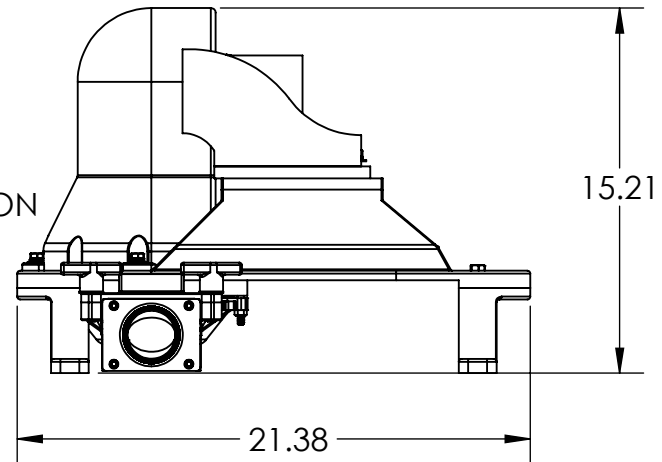
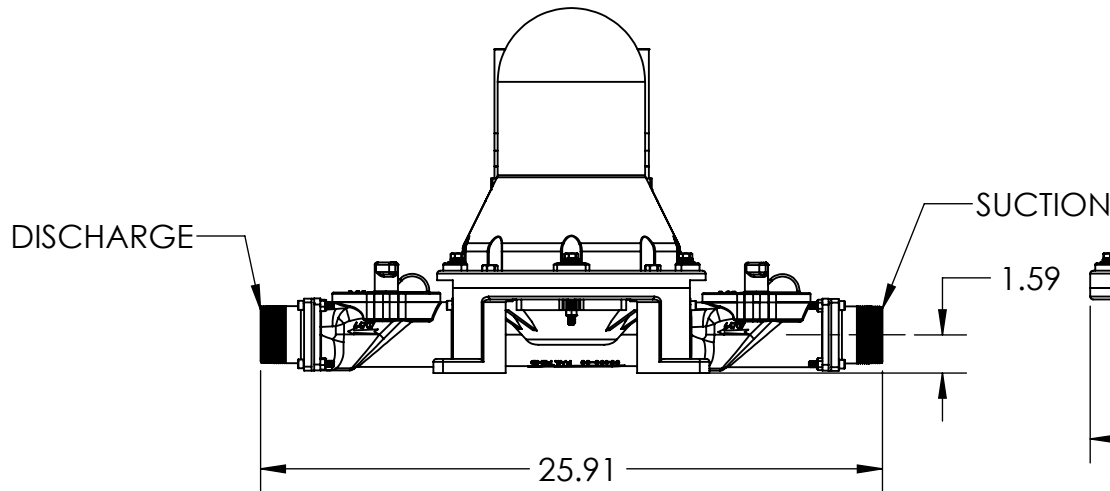
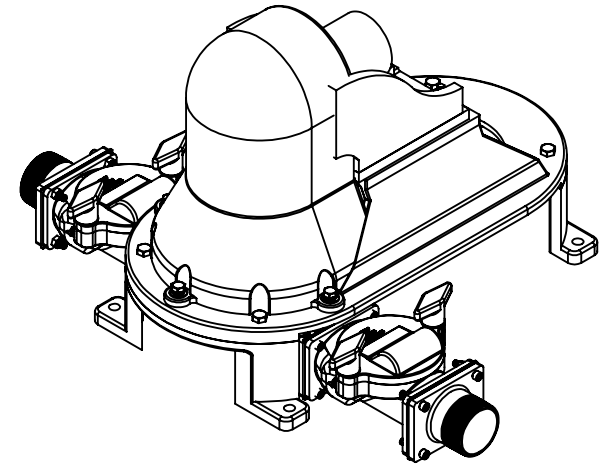
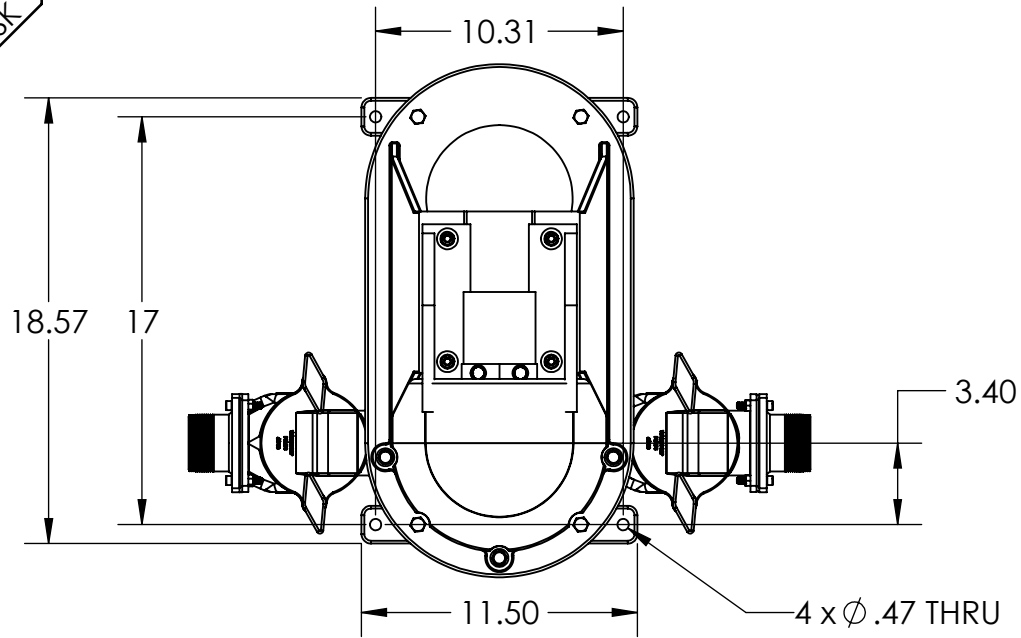

ALL INFORMATION CONTAINED IN THIS DOCUMENT IS BOTH CONFIDENTIAL AND PROPRIETARY TO WASTECORP. NO LICENSE, EXPRESSED OR IMPLIED, UNDER ANY PATENT, COPYRIGHT, OR TRADE SECRET IS GRANTED OR IMPLIED BY THE CONVEYANCE OF THIS DOCUMENT. NO PART OF THIS DOCUMENT MAY BE REPRODUCED, TRANSMITTED, TRANSCRIBED, STORED IN A RETRIEVAL SYSTEM, TRANSLATED TO ANY LANGUAGE OR COMPUTER LANGUAGE, IN ANY FORM BY ANY MEANS ELECTRONIC, MECHANICAL, OR OTHERWISE WITHOUT WASTECORP CONCENT.

THIRD ANGLE  
  
 DIMENSIONS ARE IN INCHES

A	INITIAL RELEASE	02/13/17	MT	JD
LTR.	REVISION	DATE	BY	APP.
TITLE				

MUD SUCKER 2FAC-HP

TOLERANCES UNLESS OTHERWISE SPECIFIED			
1. ANGULAR	±1/2°		
2. FRACTIONAL FINISH DIM	±.005"		
3. FRACTIONAL FINISHED DIM	± 1/8" FOR CASTING		
4. FRACTIONAL FINISHED DIM	± 1/16" FOR STEEL		
5. PART TO BE FREE OF BURRS			
6. FINISH SHOWN IN R.M.S.	030° CUT OFF		

PATTERN MAKER TOLERANCES	
± 1/32" NON ACCUMULATIVE ON FINISHED SURFACES	
1/16" FINISH ON FINISHED SURFACES UP TO 8"	
3/16" FINISH ON FINISHED SURFACES OVER 8"	

DRAWN	MT	CHKD	MJ
PR ENG		APPD	JD
SCALE	1:3		
DATE	January 17, 2019		



DRAWING NUMBER	64810-00
SHEET 1 OF 1	

5

4

3

2

1