



Coupling Foot 801985

### PRODUCT DETAILS

The Bianco PDG is a pump model proven in service for many years. Suitable for pumping biological wastewater / sewage in applications requiring high head pressures. With its robust cast iron construction and proven high carbon martensitic stainless steel macerating ring solids and fibrous matter are ground into small particles that can be safely pumped through small diameter piping

### APPLICATIONS

- Intermittent duty pumping sanitary sewage
- Suitable for pumping biological wastewater / sewage
- Pressure sewer applications

### FEATURES

- Cast iron body
- High carbon martensitic stainless steel macerating ring
- Free standing or coupling foot options

### TECHNICAL DATA

OUTPUT POWER (KW)	1.1kW P2
MOTOR NO LOAD W	640 W
MAX. HEAD [M]	90M
MAX. FLOW L/MIN	50 l/min
LIQUID TEMPERATURE	2 - 40 deg C
MAXIMUM TEMPERATURE	50 deg C
MOTOR	4 pole induction motor
MOTOR INSULATION	B Class insulation
MOTOR PROTECTION	In-built thermal overload
PROTECTION CLASS	IP68
GROSS WEIGHT (KG)	40 kg

RATED VOLTAGE	220 - 240V 1Ph 50 Hz
CURRENT	10.7 amps
START CAPACITOR	300uF 450V
RUN CAPACITOR	30uF 450V
POWER CABLE	9.5m long 10 amp rated H07 flex 10 amp 3 pin plug
MAX SUBMERGENCE	6.5 m
AUTOMATIC OPERATION	Yes - Float Switch
PUMP BODY	Cast Iron
INTERNALS	Stainless rotor / Elastomer stator
MECHANICAL SEAL	Silicon Carbide / Silicon Carbide
OUTLET	1 1/4" BSPF

## CURVE AND DIMENSIONS

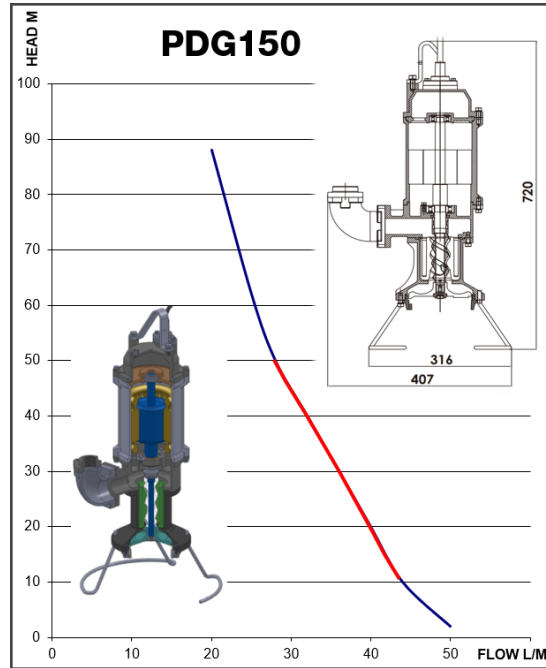

## SPARES

801978	(14) Screw Rotor
801979	(14) Stator Rubber
801980	(15a) Stator Cover
801981	(20) Mechanical Seal
801982	(16) Cutter
801983	(17) Cutter Ring
801985	Coupling Foot
805649	300uF Start Capacitor
805650	30uF Run Capacitor

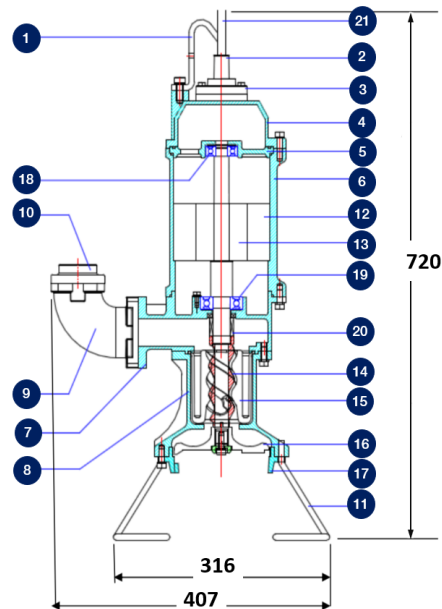

## WARRANTY / CERTIFICATIONS

