

76-100 SERIES

Stainless Steel Ball Valve with Mounting Pad 1/4" - 1"

Female NPT Thread, 2000 CWP (psig). Cold Non-Shock. (See referenced P/T chart)
 150 psig Saturated Steam.
 Vacuum Service to 29 inches Hg.
 MSS SP-110 compliant.



FEATURES

- Investment cast components
- Reinforced seats
- Mounting pad for easy actuator mounting
- Blow-out-proof stem design
- Adjustable packing gland
- Stainless Steel lever and nut

- Fire safe to API 607 (requires -24 suffix)
- Meets NACE MR0175 (2000) & MR0103 (2012)
- CSA CGA 3.16-M88 (Requires "GS" suffix)
- NSF/ANSI 61 Section 8, Annex G
- NSF-372, Drinking Water System Components - Lead Content

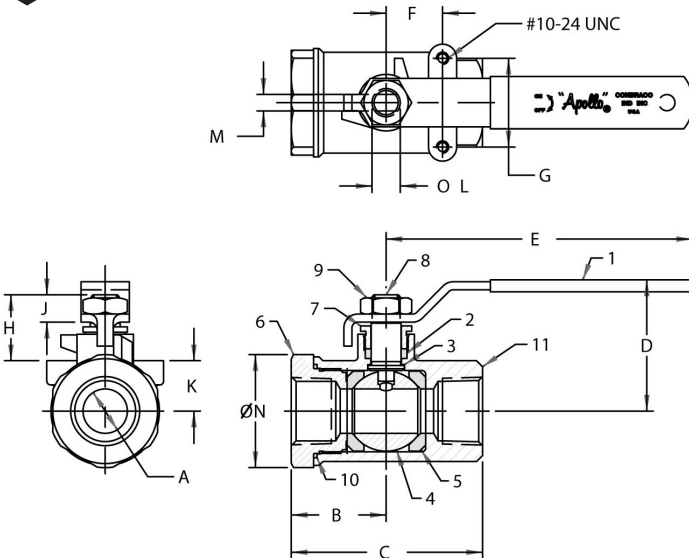

OPTIONS AVAILABLE: (More information in Section J)

- Minimum quantities apply
- To specify an option, replace the "01" standard suffix with the suffix of the option.
- To specify multiple options, replace the "01" suffix with the desired suffixes in the numerical order shown below. NOTE: Not all suffixes can be combined together.

(SUFFIX)	OPTION	SIZES
-01	Standard Configuration	All
-P -01-	BSPP (Parallel) Thread Connection	1/4" to 3"
-T -01-	BSPT (Tapered) Thread Connection	1/4" to 3"
-02-	Stem Grounded	1/4" to 3"
-04-	2.25" Stem Extension (Carbon Steel, Zinc Plated)	1/4" to 3"
-07-	Steel Tee Handle	1/4" to 2"
-08-	90° Reversed Stem	1/4" to 3"
-14-	Side Vented Ball (Uni-Directional)	1/4" to 2"
-15-	Wheel Handle, Steel	1/4" to 2"
-16-	Chain Lever - Vertical	3/4" to 2"
-19-	Lock Plate	1/4" to 2"
-21-	UHMWPE Trim (Non-PTFE)	1/4" to 3"
-24-	Graphite packing, PTFE body seal, RPTFE bearing (Fire Safe API 607, 6th edition, ISO 10497:2010)	1/4" to 3"
-27-	SS Latch-Lock Lever & Nut	1/4" to 3"
-30-	Cam-Lock and Grounded	1/4" to 2"
-32-	SS Tee Handle & Nut	1/4" to 2"
-35-	PTFE Trim	1/4" to 3"
-39-	SS Hi-Rise Locking Wheel Handle, SS Nut	1/4" to 2"
-40-	Cyl-Loc and Grounded	1/4" to 2"
-44-	Seal Welded	1/4" to 2"
-45-	Less Lever & Nut	1/4" to 3"
-46-	Latch Lock Lever - Lock in Closed Position Only	1/4" to 3"
-47-	SS Latch Lock Oval Handle	1/4" to 2"
-48-	SS Oval Handle (No Latch) & Nut	1/4" to 2"
-49-	No Lubrication. Assembled Dry.	1/4" to 3"
-50-	2.25" CS Locking Stem Extension	1/4" to 3"
-57-	Oxygen Cleaned	1/4" to 3"
-58-	Chain Lever - Horizontal	3/4" to 2"
-60-	Static Grounded Ball & Stem	1/4" to 3"
-64-	250# Steam Trim (MPTFE Seats & Packing)	1/4" to 3"
-GS	CSA CGA 3.16	All

STANDARD MATERIAL LIST

PART	MATERIAL	
1	Lever and grip	304 SS w/vinyl
2	Stem packing	MPTFE
3	Stem bearing	RPTFE
4	Ball	A276-316 Stainless Steel
5	Seat (2)	RPTFE
6	Retainer	A351-CF8M SS or A276-316 SS
7	Gland nut	A276-316 Stainless Steel
8	Stem	A276-316 Stainless Steel
9	Lever nut	18-8 Stainless Steel
10	Body seal	PTFE
11	Body	A351-CF8M Stainless Steel

PRODUCT NUMBER	SIZE	A	B	C	D	E	F	G	H	J	K	L	M	N	WT.
76-101-01A	1/4"	0.37	1.02	2.05	1.71	3.85	0.50	1.12	0.88	0.34	0.53	0.375	0.234	1.16	0.58
76-102-01A	3/8"	0.37	1.02	2.05	1.71	3.85	0.50	1.12	0.88	0.34	0.53	0.375	0.234	1.16	0.55
76-103-01A	1/2"	0.50	1.12	2.23	1.79	3.85	0.50	1.12	0.90	0.34	0.59	0.375	0.234	1.38	0.63
76-104-01A	3/4"	0.68	1.47	2.96	2.03	4.75	0.87	1.37	1.02	0.42	0.78	0.437	0.256	1.75	1.30
76-105-01A	1"	0.87	1.67	3.34	2.16	4.75	0.87	1.37	1.02	0.42	0.91	0.437	0.256	1.94	1.60

* LEAD FREE: The wetted surfaces of this product shall contain no more than 0.25% lead by weighted average. Complies with Federal Public Law 111-380. ANSI 3rd party approved and listed.

FOR PRESSURE/TEMPERATURE RATINGS, REFER TO PAGE M-14, GRAPH NO. 14

76-100 SERIES

Stainless Steel Ball Valve with Mounting Pad 1.25" - 2"

Female NPT Thread, 1500 CWP (psig). Cold Non-Shock. (See referenced P/T chart)
 150 psig Saturated Steam.
 Vacuum Service to 29 inches Hg.
 MSS SP-110 compliant.



FEATURES

- Investment cast components
- Reinforced seats
- Mounting pad for easy actuator mounting
- Blow-out-proof stem design
- Adjustable packing gland
- Stainless Steel lever and nut

- Fire safe to API 607 (requires -24 suffix)
- Meets NACE MR0175 (2000) & MR0103 (2012)
- CSA CGA 3.16-M88 (Requires "GS" suffix)
- NSF/ANSI 61 Section 8, Annex G
- NSF-372, Drinking Water System Components - Lead Content

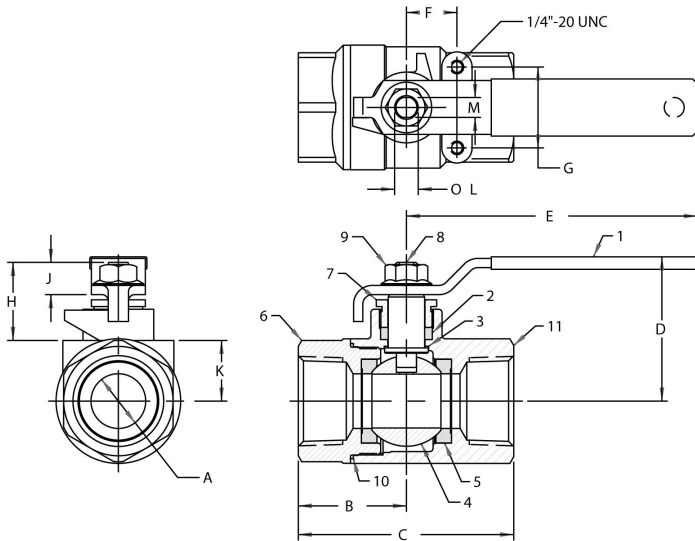

OPTIONS AVAILABLE: (More information in Section J)

- Minimum quantities apply
- To specify an option, replace the "01" standard suffix with the suffix of the option.
- To specify multiple options, replace the "01" suffix with the desired suffixes in the numerical order shown below. NOTE: Not all suffixes can be combined together.

(SUFFIX)	OPTION	SIZES
-01-	Standard Configuration	All
-P -01-	BSPP (Parallel) Thread Connection	1/4" to 3"
-T -01-	BSPT (Tapered) Thread Connection	1/4" to 3"
-02-	Stem Grounded	1/4" to 3"
-04-	2.25" Stem Extension (Carbon Steel, Zinc Plated)	1/4" to 3"
-07-	Steel Tee Handle	1/4" to 2"
-08-	90° Reversed Stem	1/4" to 3"
-14-	Side Vented Ball (Uni-Directional)	1/4" to 2"
-15-	Wheel Handle, Steel	1/4" to 2"
-16-	Chain Lever - Vertical	3/4" to 2"
-19-	Lock Plate	1/4" to 2"
-21-	UHMWPE Trim (Non-PTFE)	1/4" to 3"
-24-	Graphite packing, PTFE body seal, RPTFE bearing (Fire Safe API 607, 6th edition, ISO 10497:2010)	1/4" to 3"
-27-	SS Latch-Lock Lever & Nut	1/4" to 3"
-30-	Cam-Lock and Grounded	1/4" to 2"
-32-	SS Tee Handle & Nut	1/4" to 2"
-35-	PTFE Trim	1/4" to 3"
-39-	SS Hi-Rise Locking Wheel Handle, SS Nut	1/4" to 2"
-40-	Cyl-Loc and Grounded	1/4" to 2"
-44-	Seal Welded	1/4" to 2"
-45-	Less Lever & Nut	1/4" to 3"
-46-	Latch Lock Lever - Lock in Closed Position Only	1/4" to 3"
-47-	SS Latch Lock Oval Handle	1/4" to 2"
-48-	SS Oval Handle (No Latch) & Nut	1/4" to 2"
-49-	No Lubrication. Assembled Dry.	1/4" to 3"
-50-	2.25" CS Locking Stem Extension	1/4" to 3"
-57-	Oxygen Cleaned	1/4" to 3"
-58-	Chain Lever - Horizontal	3/4" to 2"
-60-	Static Grounded Ball & Stem	1/4" to 3"
-64-	250# Steam Trim (MPTFE Seats & Packing)	1/4" to 3"
-GS	CSA CGA 3.16	All

STANDARD MATERIAL LIST

PART	MATERIAL
1 Lever and grip	304 SS w/vinyl
2 Stem packing	MPTFE
3 Stem bearing	RPTFE
4 Ball	A276-316 Stainless Steel
5 Seat (2)	RPTFE
6 Retainer	A351-CF8M Stainless Steel
7 Gland nut	A276-316 Stainless Steel
8 Stem	A276-316 Stainless Steel
9 Lever nut	18-8 Stainless Steel
10 Body seal	PTFE
11 Body	A351-CF8M Stainless Steel

PRODUCT NUMBER	SIZE	A	B	C	D	E	F	G	H	J	K	L	M	WT.
76-106-01	1.25"	1.00	2.00	4.00	2.68	5.40	0.94	1.50	1.50	0.60	1.12	0.625	0.377	3.10
76-107-01	1.5"	1.25	2.17	4.34	3.25	7.75	0.94	1.50	1.50	0.60	1.28	0.625	0.377	4.20
76-108-01	2"	1.50	2.69	5.43	3.24	7.75	0.94	1.50	1.46	0.60	1.50	0.625	0.377	6.10

*LEAD FREE: The wetted surfaces of this product shall contain no more than 0.25% lead by weighted average. Complies with Federal Public Law 111-380. ANSI 3rd party approved and listed.

FOR PRESSURE/TEMPERATURE RATINGS, REFER TO PAGE M-13, GRAPH NO. 12



76-100 SERIES

Stainless Steel Ball Valve 2.5" - 3"

Female NPT Thread, 1000 CWP (psig). Cold Non-Shock. (See referenced P/T chart)
 150 psig Saturated Steam.
 Vacuum Service to 29 inches Hg.
 MSS SP-110 compliant.



FEATURES

- Investment cast components
- Reinforced seats
- Mounting pad for easy actuator mounting
- Blow-out-proof stem design
- Adjustable packing gland

- Stainless Steel lever and nut
- Fire safe to API 607 (requires -24 suffix)
- Meets NACE MR0175 (2000) & MR0103 (2012)
- CSA CGA 3.16-M88 (Requires "GS" suffix)
- NSF/ANSI 61 Section 8, Annex G
- NSF-372, Drinking Water System Components - Lead Content

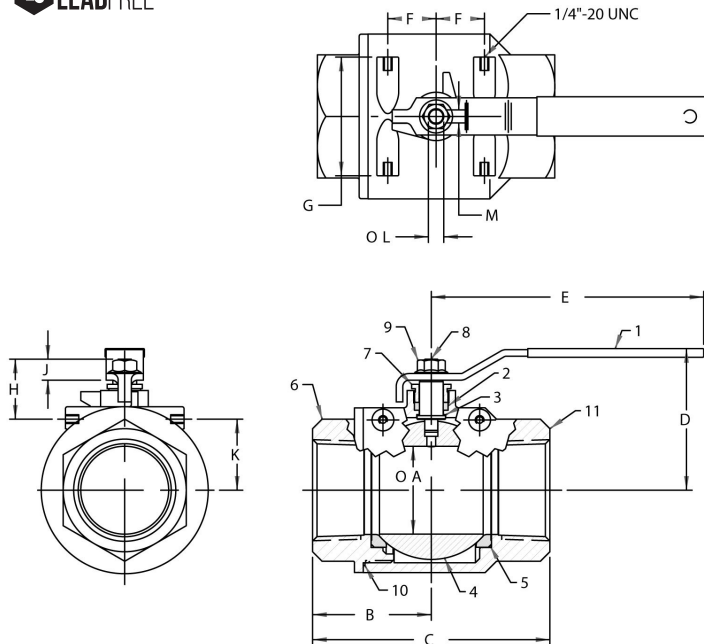

OPTIONS AVAILABLE: (More information in Section J)

- Minimum quantities apply
- To specify an option, replace the "01" standard suffix with the suffix of the option.
- To specify multiple options, replace the "01" suffix with the desired suffixes in the numerical order shown below. NOTE: Not all suffixes can be combined together.

(SUFFIX)	OPTION	SIZES
-01	Standard Configuration	All
-02-	Stem Grounded	1/4" to 3"
-04-	2.25" Stem Extension (Carbon Steel, Zinc Plated)	1/4" to 3"
-07-	Steel Tee Handle	1/4" to 2"
-08-	90° Reversed Stem	1/4" to 3"
-14-	Side Vented Ball (Uni-Directional)	1/4" to 2"
-15-	Wheel Handle, Steel	1/4" to 2"
-16-	Chain Lever - Vertical	3/4" to 2"
-19-	Lock Plate	1/4" to 2"
-21-	UHMWPE Trim (Non-PTFE)	1/4" to 3"
-24-	Graphite packing, PTFE body seal, RPTFE bearing (Fire Safe API 607, 6th edition, ISO 10497:2010)	1/4" to 3"
-27-	SS Latch-Lock Lever & Nut	1/4" to 3"
-30-	Cam-Lock and Grounded	1/4" to 2"
-32-	SS Tee Handle & Nut	1/4" to 2"
-35-	PTFE Trim	1/4" to 3"
-39-	SS Hi-Rise Locking Wheel Handle, SS Nut	1/4" to 2"
-40-	Cyl-Loc and Grounded	1/4" to 2"
-44-	Seal Welded	1/4" to 2"
-45-	Less Lever & Nut	1/4" to 3"
-46-	Latch Lock Lever - Lock in Closed Position Only	1/4" to 3"
-47-	SS Latch Lock Oval Handle	1/4" to 2"
-48-	SS Oval Handle (No Latch) & Nut	1/4" to 2"
-49-	No Lubrication. Assembled Dry.	1/4" to 3"
-50-	2.25" CS Locking Stem Extension	1/4" to 3"
-57-	Oxygen Cleaned	1/4" to 3"
-58-	Chain Lever - Horizontal	3/4" to 2"
-60-	Static Grounded Ball & Stem	1/4" to 3"
-64-	250# Steam Trim (MPTFE Seats & Packing)	1/4" to 3"
-GS	CSA CGA 3.16	All

STANDARD MATERIAL LIST

PART	MATERIAL	
1	Lever and grip	304 SS w/vinyl
2	Stem packing	MPTFE
3	Stem bearing	RPTFE
4	Ball	A276-316 Stainless Steel
5	Seat (2)	RPTFE
6	Retainer	A351-CF8M Stainless Steel
7	Gland nut	A276-316 Stainless Steel
8	Stem	A276-316 Stainless Steel
9	Lever nut	18-8 Stainless Steel
10	Body seal	PTFE
11	Body	A351-CF8M Stainless Steel

* LEAD FREE: The wetted surfaces of this product shall contain no more than 0.25% lead by weighted average. Complies with Federal Public Law 111-380. ANSI 3rd party approved and listed.

FOR PRESSURE/TEMPERATURE RATINGS, REFER TO PAGE M-12, GRAPH NO. 8

PRODUCT NUMBER	SIZE	A	B	C	D	E	F	G	H	J	K	L	M	WT.
76-109-01	2.5"	2.50	3.38	6.75	4.03	7.75	1.38	3.37	1.71	0.60	2.00	0.625	0.377	15.60
76-100-01	3"	2.50	3.38	6.75	4.03	7.75	1.38	3.37	1.71	0.60	2.00	0.625	0.377	16.50



FLOW DATA

For Apollo® Ball Valves

The listed Cv "factors" are derived from actual flow testing, in the Apollo® Ball Valve Division, Conbraco Industries, Inc., Pageland, South Carolina. These tests were completed using standard "off the shelf" valves with no special preparation and utilizing standard schedule 40 pipe. It should be understood that these factors are for the valve only and also include the connection configuration. The flow testing is done utilizing water as a fluid media and is a direct statement of the gallons of water flowed per minute with a 1 psig pressure differential across the valve/connection unit. Line pressure is not a factor. Because the Cv is a factor, the formula can be used to estimate flow of most media for valve sizing.

FLOW OF LIQUID

$$Q = C_v \sqrt{\frac{\Delta P}{\text{SpGr}}}$$

$$\text{or } \Delta P = \frac{(Q)^2 (\text{SpGr})}{(C_v)^2}$$

Where:

Q = flow in US gpm
 ΔP = pressure drop (psig)
 SpGr = specific gravity at flowing temperature
 Cv = valve constant

FLOW OF GAS

$$Q = 1360 C_v \sqrt{\frac{(\Delta P) (P_2)}{(\text{SpGr}) (T)}}$$

$$\text{or } \Delta P = \frac{5.4 \times 10^{-7} (\text{SpGr}) (T) (Q)^2}{(C_v)^2 (P_2)}$$

Where:

Q = flow in SCFH
 ΔP = pressure drop (psig)
 SpGr = specific gravity (based on air = 1.0)
 P₂ = outlet pressure-psia (psig + 14.7)
 T = (temp. °F + 460)
 Cv = valve constant

CAUTION: The gas equation shown, is valid at very low pressure drop ratios. The gas equation is NOT valid when the ratio of pressure drop (ΔP) to inlet pressure (P1) exceeds 0.02.

NOTE: Only use the gas equation shown if (P1-P2)/P1 is less than 0.02.

Cv FACTORS FOR APOLLO VALVES

VALVE	SIZE (IN.)														
	1/4	3/8	1/2	3/4	1	1.25	1.5	2	2.5	3	4	6	8	10	12
70B-140 Series	8.4	7.2	15	30	43	48	84	108	190	370	670	--	--	--	--
70-100/200 Series	8.4	7.2	15	30	43	48	84	108	190	370	670	--	--	--	--
70-300/400 Series	--	--	15	30	43	48	84	108	--	--	--	--	--	--	--
70-600 Series	2.3	4.5	5.4	12	14	21	34	47	--	--	--	--	--	--	--
70-800 Series	8.4	7.2	15	30	43	48	84	--	--	--	--	--	--	--	--
71-AR Series	--	--	--	30	43	48	84	108	190	370	--	--	--	--	--
71-100/200 Series	--	--	--	30	43	48	84	108	190	370	--	--	--	--	--
72-100/900 Series	--	--	26	48	65	125	170	216	--	--	--	--	--	--	--
73A-100 Series	8.4	7.2	15	30	43	48	84	108	--	--	--	--	--	--	--
73-300/400 Series	--	--	26	48	65	125	170	216	--	--	--	--	--	--	--
74-100 Series	8.4	7.2	15	30	43	48	84	108	190	370	670	--	--	--	--
75-100 Series	8.4	7.2	15	30	43	48	84	108	190	370	670	--	--	--	--
76-AR Series	8.4	7.2	15	30	43	48	84	108	190	370	670	--	--	--	--
76F-100 Series	8.1	15	15	51	68	125	177	389	--	--	--	--	--	--	--
76FJ-100 Series	8.1	15	15	51	68	125	177	389	--	--	--	--	--	--	--
76FK-100 Series	8.1	15	15	51	68	125	177	389	--	--	--	--	--	--	--
76-100 Series	8.4	7.2	15	30	43	48	84	108	190	370	--	--	--	--	--
76-300/400 Series	--	--	26	48	65	125	170	216	--	--	--	--	--	--	--
76-600 Series	2.3	4.5	5.4	12	14	21	34	47	--	--	--	--	--	--	--
76J-100 Series	8.4	7.2	15	30	43	48	84	108	190	370	--	--	--	--	--
76J-AR Series	8.4	7.2	15	30	43	48	84	108	190	370	670	--	--	--	--
76K-100 Series	8.4	7.2	15	30	43	48	84	108	190	370	--	--	--	--	--
76K-AR Series	8.4	7.2	15	30	43	48	84	108	190	370	670	--	--	--	--
7K-100 Series	--	--	15	51	68	125	177	389	503	--	--	--	--	--	--
77-AR Series	8.1	15	15	51	68	125	177	389	--	--	--	--	--	--	--
77C-100/200 Series	4.5	7.2	16	36	68	125	177	389	503	--	--	--	--	--	--
77D-140 Series	4.5	7.2	16	36	68	125	177	389	--	--	--	--	--	--	--

continued on next page



FLOW DATA

For Apollo® Ball Valves

Cv FACTORS FOR APOLLO VALVES (continued from M-3)

VALVE	SIZE (IN.)														
	1/4	3/8	1/2	3/4	1	1.25	1.5	2	2.5	3	4	6	8	10	12
77D-640 Series	--	--	--	11	24	35	--	--	--	--	--	--	--	--	--
77G-UL Series	4.5	7.2	16	36	68	125	177	389	503	--	--	--	--	--	--
77W Series	--	--	16	36	68	125	177	389	--	--	--	--	--	--	--
77-100/200 Series	8.1	15	15	51	68	125	177	389	503	--	--	--	--	--	--
79 Series	8.5	8.5	9.8	32	44	66	148	218	440	390	--	--	--	--	--
80 Series	8.4	7.2	15	30	43	48	84	108	190	370	--	--	--	--	--
82-100/200 Series	8.1	14	26	51	68	120	170	376	510	996	1893	--	--	--	--
83A/83B Series	8.1	14	26	51	68	120	170	376	--	--	--	--	--	--	--
83R-100/200 Series	--	--	--	--	--	--	170	376	--	996	1893	--	--	--	--
86A/86B Series	8.1	14	26	51	68	120	170	376	--	--	--	--	--	--	--
86R-100/200 Series	--	--	--	--	--	--	170	376	--	996	1893	--	--	--	--
87A-100 Series	--	--	--	--	--	--	86	104	234	375	673	1099	1902	3890	--
87A-200 Series	--	--	15	19	75	--	195	410	545	1021	2016	4837	9250	15170	22390
87A-700 Series	--	--	--	--	--	--	86	104	234	375	673	1099	1902	3890	--
87A-900 Series	--	--	15	19	75	--	195	410	545	1021	2016	4837	9250	15170	22390
87A-F00 Series	--	--	--	--	75	--	195	410	545	1021	2016	4837	--	--	--
87B-100 Series	--	--	--	--	--	--	--	--	--	375	673	1099	1902	3890	--
87J-100 Series	--	--	--	--	--	--	86	104	234	375	673	1099	1902	3890	--
87J-200 Series	--	--	15	19	75	--	195	410	545	1021	2016	4837	9250	15170	22390
87J-700 Series	--	--	--	--	--	--	86	104	234	375	673	1099	1902	3890	--
87J-900 Series	--	--	15	19	75	--	195	410	545	1021	2016	4837	9250	15170	22390
87K-100 Series	--	--	--	--	--	--	86	104	234	375	673	1099	1902	3890	--
87K-200 Series	--	--	15	19	75	--	195	410	545	1021	2016	4837	9250	15170	22390
87K-700 Series	--	--	--	--	--	--	86	104	234	375	673	1099	1902	3890	--
87K-900 Series	--	--	15	19	75	--	195	410	545	1021	2016	4837	9250	15170	22390
88A-100 Series	--	--	--	--	--	--	86	104	234	375	673	1099	1902	3890	--
88A-200 Series	--	--	15	19	75	--	195	410	545	1021	2016	4837	9250	15170	22390
88A-700 Series	--	--	--	--	--	--	86	104	234	375	673	1099	1902	3890	--
88A-900 Series	--	--	15	19	75	--	195	410	545	1021	2016	4837	9250	15170	22390
88A-F00 Series	--	--	--	--	75	--	195	410	545	1021	2016	4837	--	--	--
88B-100 Series	--	--	--	--	--	--	--	--	--	375	673	1099	1902	3890	--
89-100 Series	8.4	7.2	15	30	43	48	84	108	190	370	--	--	--	--	--
9A-100 Series	8.3	6.7	5.7	10	16	25	40	62	--	--	--	--	--	--	--
90-100 Series	8.3	6.7	5.7	10	16	25	40	62	--	--	--	--	--	--	--
92-100 Series	8.3	6.7	5.7	10	16	25	40	62	--	--	--	--	--	--	--
93-100 Series	8.3	6.7	5.7	10	16	25	40	62	--	--	--	--	--	--	--
94A-100/200 Series	6	7	19	34	50	104	268	309	629	1018	1622	--	--	--	--
96-100 Series	8.3	6.7	5.7	10	16	25	40	62	--	--	--	--	--	--	--
399-100 Series	8.4	7.2	15	30	43	48	84	108	190	370	--	--	--	--	--
489-100 Series	8.4	7.2	15	30	43	48	84	108	190	370	--	--	--	--	--

PRESSURE TEMPERATURE RATINGS

2000 CWP

(CS) ASTM A216-WCB or A105

(GRAPH 13)

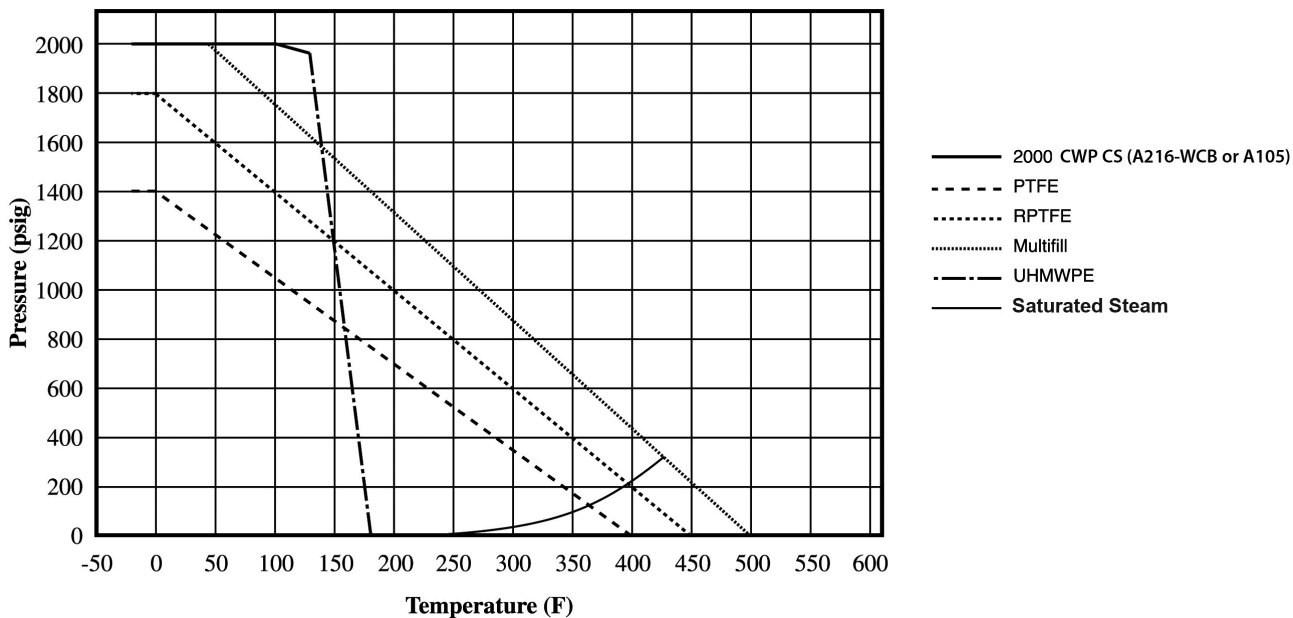

2000 CWP

(SS) ASTM A351-CF8M

(GRAPH 14)

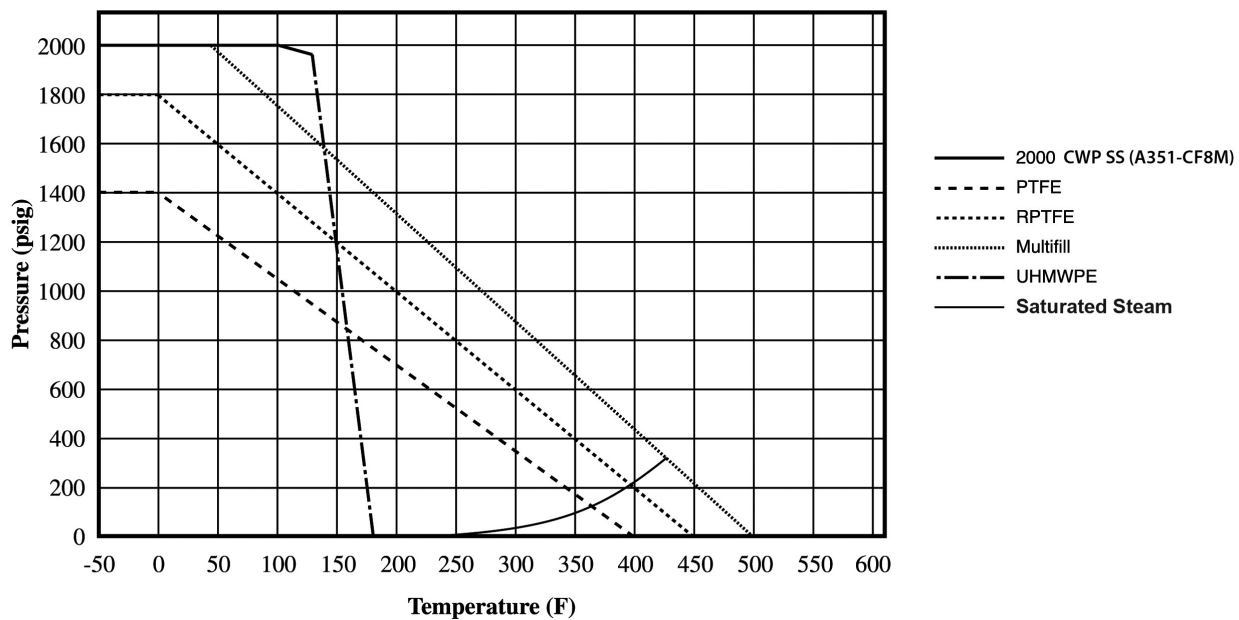

PRESSURE TEMPERATURE RATINGS

1500 CWP

(CS) ASTM A216-WCB or ASTM A105

(GRAPH 11)

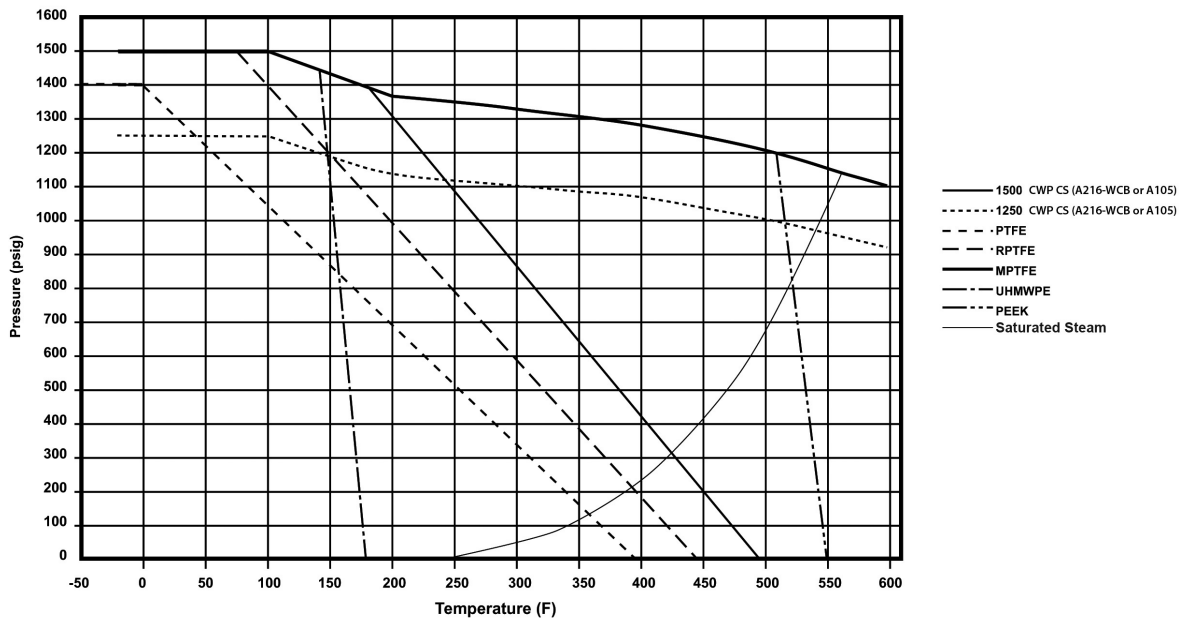

1500 CWP

(SS) ASTM A351-CF8M

(GRAPH 12)

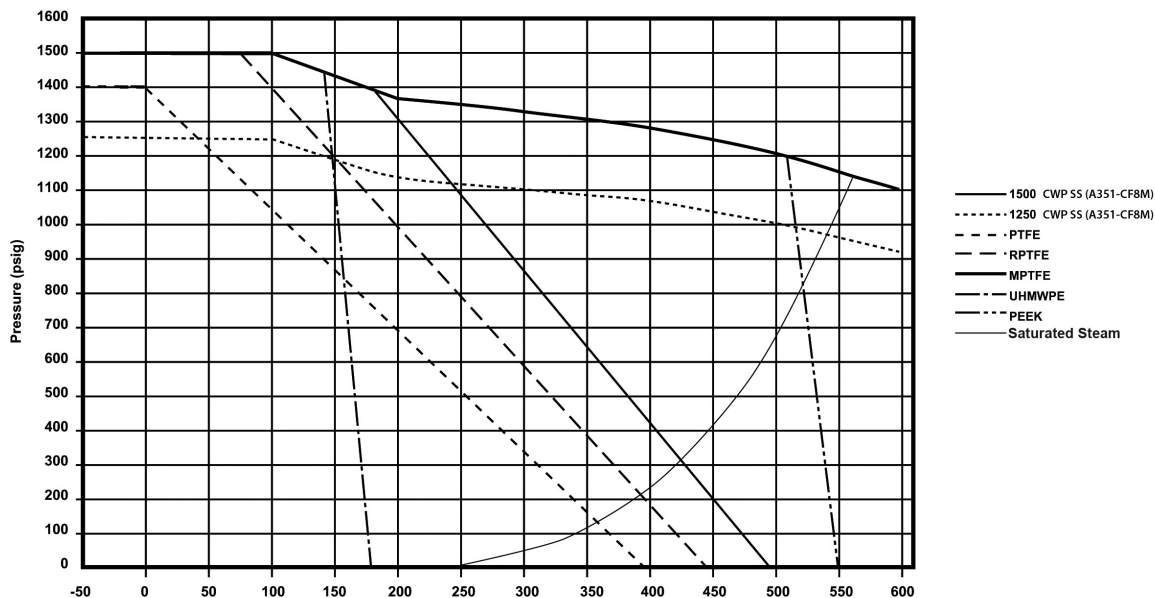

PRESSURE TEMPERATURE RATINGS

1000 CWP

(CS) ASTM A216-WCB

(GRAPH 7)

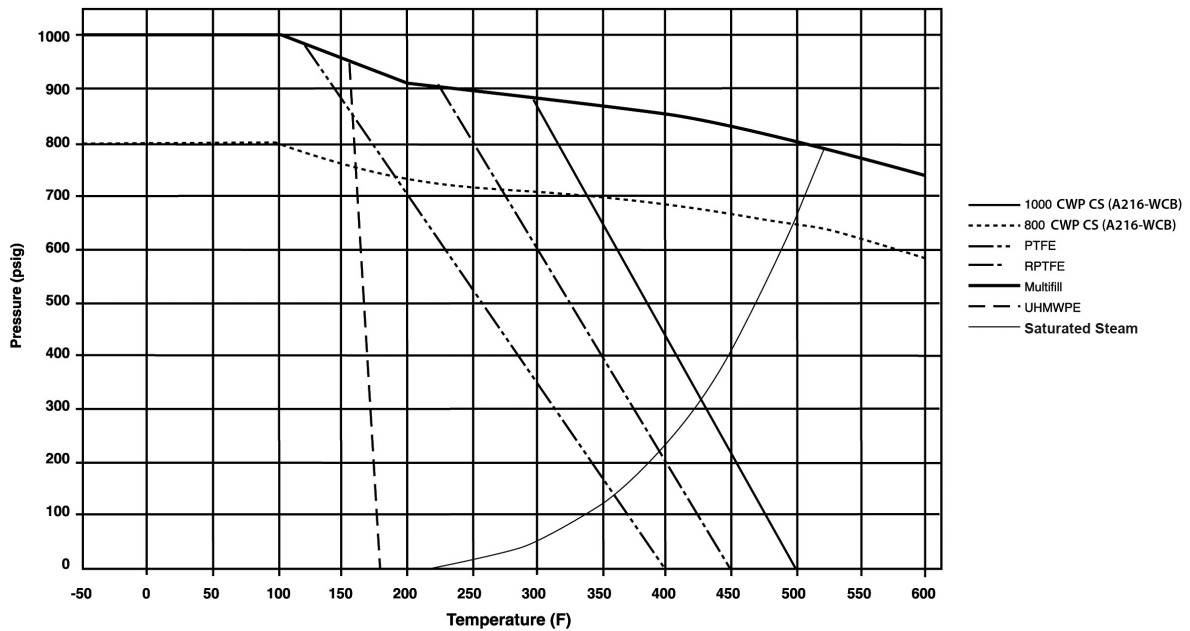

1000 CWP

(SS) ASTM A351-CF8M

(GRAPH 8)

