

DAVEY



5155H with
Honda GX
Motor

DAVEY Firefighter®

Model Number:
5155H, 5155H3, 5155HV, 5165H,
5165HE, 5165HQ

WARRANTY
Up to 5 YEARS - Wet end**
3 YEARS - Honda GX motors

APPLICATIONS

Ideal for firefighting, tanker to tanker water transfer, high head general water transfer, sheep jetting, irrigation.

RUGGED, ECONOMICAL SINGLE STAGE ENGINE DRIVEN WATER TRANSFER PUMP

FEATURES & BENEFITS

- **Driven by a Honda GX160 or GX200 engine.**
The GX200 engine is also available in electric start.
- **Patented clamped impeller design** to enable longer impeller life and easier disassembly in case of blockage
- **Single stage design** provides the versatility of high flow rates with strong pressure
- **Thrust balanced impeller design** to extend engine life
- Pump casing, diffusers and impellers **manufactured from quality corrosion resistant marine grade aluminium** for long life
- **Choice of 3 or 4 way discharge port** for easy installation with a choice of plumbing sizes
- **Polyester coated pump casing, exterior and interior**, for added corrosion resistance
- **Patented floating impeller neckrings front and back** help improve pumping efficiency and extend seal life, dramatically reducing engine wear
- **Self priming from 7m** for more versatile installation options
- **Large priming and drain port with bayonet fit plugs** to accept pressure gauges or drain cocks
- **Low-oil protection on all models** to protect your engine
- **“HE” (electric start models) have electric starter and recoil starter fitted** to ensure a choice of starting methods, even if the battery is flat or removed
- **“HV” models come with Viton seal, o-rings, gaskets, caps etc. fitted** for improved chemical resistance. (Please seek specialist advice from chemical supplier if pumping chemicals. Use of aggressive chemicals may void warranty.)
- **All engines conform to the tough environmental requirements of the USA EPA and CARB standards**, to help look after the environment

Engine Driven Pumps



OPERATING LIMITS	
Flow capacities to	500 L/min
Maximum total head	72m
Maximum suction lift	7m
Maximum water temperature	50°C
Minimum water temperature	1°C
Maximum casing pressure	1000kPa
Minimum suction pipe size	1 1/2"
Suction pipe strainer	Required
Inlet size*	1 1/2" or 2"

*Dependant upon model chosen

ENGINE SPECIFICATIONS			
Single Stage Pump Model	5155H 5155H3 5155HV	5165H 5165HQ	5165HE
Engine brand	Honda		
Engine model	GX160	GX200	GX200E
Engine type	Overhead valve		
Displacement (cc)	163	196	
Fuel tank (litres)	3.1		
Oil capacity (litres)	0.6		
Compression ratio	8.5 : 1		
Air filter type	Twin stage - foam prefilter with paper element final filter		
Spark arrestor	YES		
Approximate fuel consumption @ full load @ 3600 rpm	1.7 L/hr		
dBa @ 4m @ 3600 rpm @ full head	85	86	

MATERIALS OF CONSTRUCTION	
PART	MATERIAL
Suction cover	Marine grade aluminium (AS605)
Diffuser	Marine grade aluminium (AS605)
Impeller	Marine grade aluminium (AS605)
Casing / yoke	Marine grade aluminium (AS605)
Mechanical seal	Carbon / Ceramic
Discharge / handle	Marine grade aluminium (AS605)
Casing bolts	Zinc plated steel
Yoke bolts	Stainless Steel
Flap valve / seal ring	Zinc body, hytrel seal
Neck ring, priming and drain plug	Glass filled nylon
Casing, priming and drain plug o-ring	Nitrile rubber
Discharge gasket	Hytrel
Paint finish	Baked polyester powder coat

DIMENSIONS (mm)									
Model	A	B	C	D	E	Inlet BSP	Outlet BSP	No. of Outlets	Net Weight (kg)
5155H*	605	450	410	194	321	1 1/2"M	2x1"M 2x1 1/2"M	4 way	25
5155H3	445	388	388	169	296	1 1/2"M	1x1 1/2"M 2x1"M	3 way	25
5155HV	445	388	388	169	296	1 1/2"M	2x1"M 2x1 1/2"M	4 way	25
5165H*	605	450	410	194	321	1 1/2"M	2x1"M 2x1 1/2"M	4 way	26
5165HQ	510	388	402	169	296	2"M	1x1 1/2"M 2x1"M	3 way	26
5165HE	510	388	402	169	296	1 1/2"M	2x1"M 2x1 1/2"M	4 way	29

*Dimensions and weight includes supplied frame as pictured

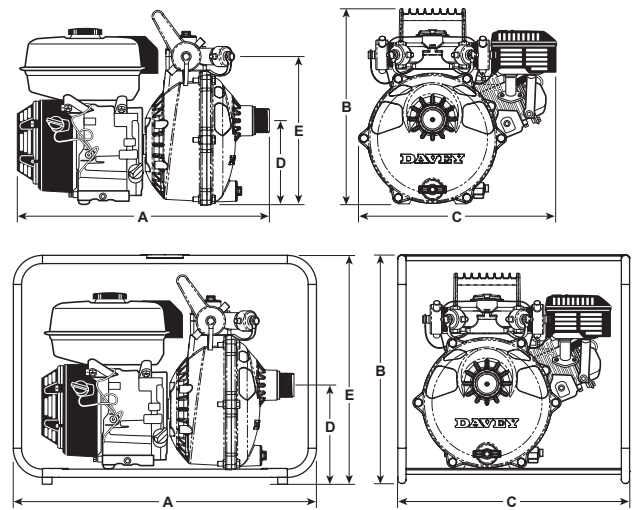

*Dimensions for 5155H and 5165H only.

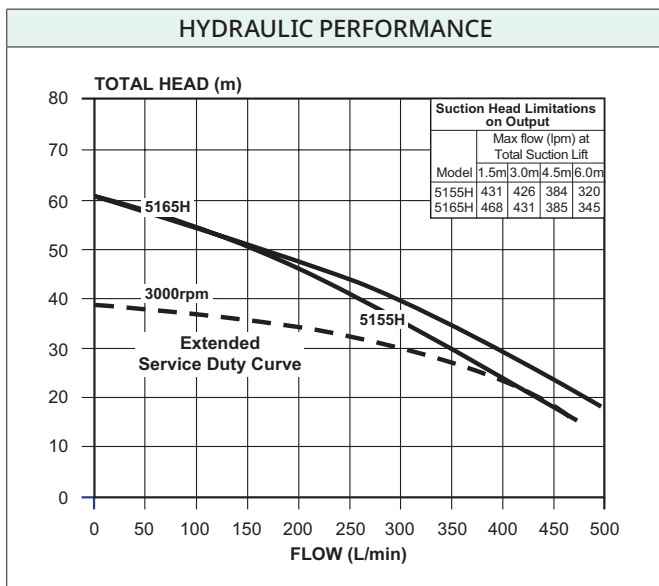

**NOTE: Standard 3 year warranty from point of purchase, and up to 5 years total warranty, when serviced between the start of Year 2 and the end of Year 3 by a registered Davey Service Agent with proof of service.



daveywater.com

This literature is not a complete guide to product usage. All images provided in this document are for illustration purposes only. Further information is available from your Davey Dealer, Davey Support Centre and from the relevant product Installation and Operating Instructions. Must be read in conjunction with the relevant product Installation and Operating Instructions and all applicable statutory requirements. Product specifications may change without notice. © Davey is a registered trademark of Davey Water Products Pty Ltd. © Davey Water Products Pty Ltd 2025.

