



FUEL MANAGEMENT SYSTEMS



DISPENSERS



KITS



PUMPS



METERS



NOZZLES

K700 PULSER

FEATURES

- EASY TO INSTALL AND TO CALIBRATE
- VERSATILE
- HIGH FLOW RATE
- HEAVY DUTY
- INDUSTRIAL APPLICATIONS

The PIUSI K700 PULSER is an oval gear electronic meter with acetal resin gears. This pulse meter easily interfaces with management systems, making it the ideal solution to fit fuel distributors. It is also suitable for tanks and cisterns, loading arms controlling the consumption of fuel in burners or generator sets, besides other applications.

PERFORMANCE

25-250

L/MIN

FLOW RATE

20 BAR

MAX

OPERATING PRESSURE

± 0,5%

ACCURACY

0,2%

REPEATABILITY



K700 PULSER



PACKAGING

CODE	WEIGHT		PACKAGING		
	KG	LBS	MM	INCH	PCS/BOX

PULSER

FOO49800A	5,5	12	280X160X140	11X6,3X5,5	1
-----------	-----	----	-------------	------------	---



FILTRATION



TANK MONITORING



HOSE REEL



ACCESSORIES



MERCHANDISE

PIUSI

BS

ANY BIODIESEL

A

AIR

A

ANTIFREEZE

Ad

AdBlue®

B

BIODIESEL

D

DIESEL

F

FOOD

G

GASOLINE

G

GREASE

K

KEROSENE

O

OIL

W

WATER

W

WINDSCREEN

CHART



IN THE BOX

- K700 PULSER METER
- INSTRUCTION MANUAL

DETAILS



INBUILT SUCTION FILTER



OVAL GEARS

DIMENSIONS

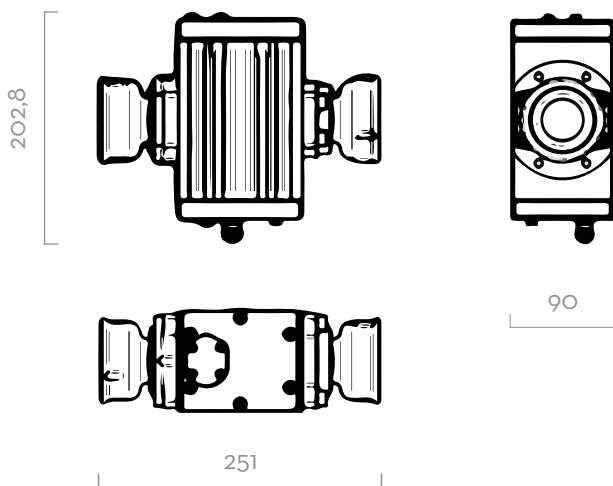

Dimensions expressed in millimeters

MATERIALS

- BODY: ALUMINIUM
- GEARS: TECHNOPOLYMER

TECHNICAL DATA

CODE	DESCRIPTION	FLUIDS TYPE	FLOW RATE		PULSER		PRESSURE		BATTERY N°2 X 1,5V (INCLUDED)	FLANGE	INLET / OUTLET	INLET FILTER
			L/MIN	GPM	P/L	GPM	BAR	PSI				
FOO49800A	K700 PULSER	A B D O	25 - 250	6,6 - 66	14	53	20	300	NO	YES	2" BSP	YES

PULSER

UPON REQUEST AVAILABLE IN NPT VERSION.