

## 1-YS SERIES - 1/150 HP

### APPLICATIONS

This parts washer pump is for use with Stoddard solvent and deodorized kerosene submerged parts washer applications only. These refined petroleum distillates from the parts washer pump are free from the tendency to heat spontaneously and have a closed cup flash point no lower than 100 °F (37.8 °C).

### FEATURES

- Oil-filled aluminum housing
- Nylon volute and impeller
- Conduit fitting for mounting
- Submerged use only in parts washers
- Fluoroelastomer (FKM) shaft seal
- For use with UL (PIQU) solvents
- 6-foot power cord, no plug
- Thermally protected



1-YS



### SERIES SPECIFICATIONS

Item No.	Model	Discharge	Listing	HP	Volts	Hz	Amps	Watts	Gallons per hour (Liter per hour) @ Height			Shut-Off	PSI	Cord	Weight lbs (Kg)
									1'	3'	5'				
501020	1	1/4" MNPT	UR/C-CSA	1/150	115	60	1.1	70	205 (776)	168 (636)	120 (454)	7.4' (2.26 m)	3.2	6' (1.8 m)	3.5 (1.59 Kg)
501036	1-YS	1/4" MNPT		1/150	230	50/60	0.6	70	205 (776)	168 (636)	120 (454)	7.4' (2.26 m)	3.2	6' (1.8 m)	3.5 (1.59 Kg)

# SPECIALTY PUMPS

## 1-YS SERIES - 1/150 HP

### ENGINEERING DATA

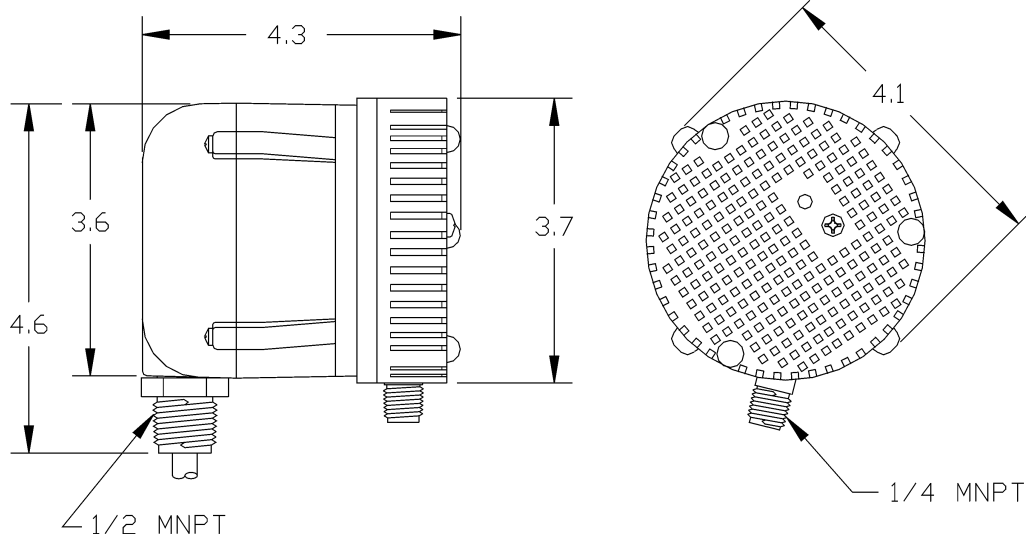

### PERFORMANCE DATA

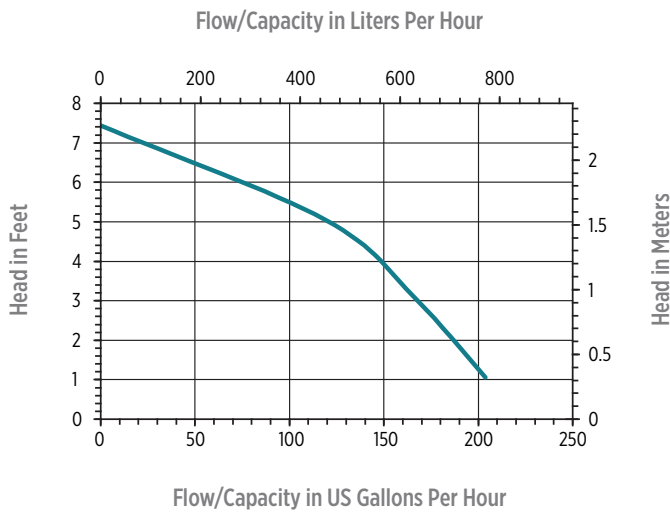

### REPLACEMENT PARTS

<b>Volute</b>	101351
<b>Impeller</b>	101433
<b>Screen</b>	101351

