

EN INTRODUCTION

The 1-YS pump is designed for submerged use only. Its motor is hermetically sealed in a diecast aluminum housing, which is oil-filled for heat transfer and permanent lubrication. It is intended to pump unheated metal parts-cleaning solvent that is UL classified as PJQU as described in the Gas and Oil Equipment Directory. These are refined petroleum distillates that are free from the tendency to heat spontaneously. They have a closed cup flash point not lower than 100 degrees F. These are typical fluids that are compatible with the pump materials (except the power cord.) See Installation step 1.

NOTE: This pump is intended for use only in parts cleaners listed by Underwriters Laboratories. The combination of the fluid pumped, the pump, and the design of the parts washer will determine if additional safety devices, such as a low liquid level cut off, are required. Refer to parts washer manufacturer's instructions to see if this is required.

SAFETY GUIDELINES



Before servicing the pump, see solvent and equipment manufacturer's instructions for further safety information and possible hazards.

Follow all local electrical and safety codes, as well as the National Electrical Code (NEC) and the Occupational Safety and Health Act (OSHA).

This pump must be properly grounded while in use to protect the operator from electrical shock.

Always disconnect power source before working on the pump. If the power disconnect point is out of sight, lock in the open position and tag to prevent unexpected application of power.

Do not attempt to make your own parts cleaners.

The low flash point of these combustible liquids does present a moderate fire hazard. Operating the pump fully submerged offers added protection from fire risk. For other solvent handling precautions, consult the material safety data sheet (OSHA-20 form, or equivalent) for the solvent used.

Use only UL-approved metal parts cleaning solvents. The use of fluids such as gasoline and lower flash point solvents is dangerous and may cause explosions or fire. Solvents other than UL-approved metal parts cleaning solvents will void the warranty of this product.

SPECIFICATIONS

Suction inlet	Smooth opening, approx. 1/2" I.D.
Discharge outlet	1/4" NPT (male)
Cord type	18/3 (SJTO)
Pipe connector around cord	1/2" NPT (male)
Pump housing (volute)	Nylon
Motor housing	Die-cast aluminum (unpainted)
Impeller	Nylon (with S.S. bushing)
Pump screen	Polyethylene
Pump shaft seal	Fluoroelastomer (FKM)
Motor shaft	440 S.S.
Volute & pump screws	410 S.S. or 18-8 S.S.
Overall dimensions	4" dia. x 4-1/4" height
Maximum fluid temperature	100° F

INSTALLATION



WARNING: Do not allow the pump's power cord to come in contact with solvent. The solvent may damage the cord insulation, causing the cord to become stiff or lower its insulating properties. The pump is supplied with a three-conductor power cord. The third conductor is to ground the pump to prevent possible electrical shock hazard.

1. Seal the power cord inside of liquid-tight, 1/2" NPT steel intermediate metal conduit. Use caution to ensure that cord will not be nicked or cut.
2. Consult pump nameplate data for proper voltage and frequency. Please note, the black (or brown) and white (or blue) wires are live and the green (or green/yellow) wire is ground.
3. Be sure that the pump is fully submerged in the cleaning solvent.
4. The pump power supply cord must be connected to a properly grounded, grounding-type receptacle.

PERFORMANCE

(115V 60HZ)

MODEL	GALLONS PER HOUR				SHUT-OFF PSI
	1'	3'	5'	7.5'	
1-YS	180	144	102	0	3.2

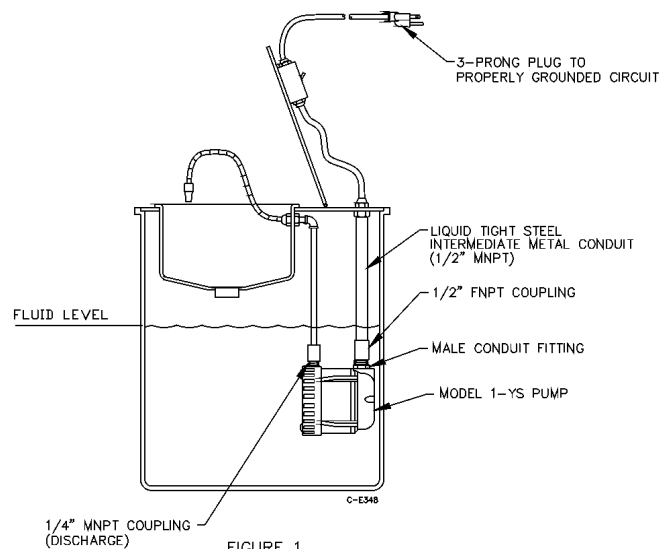

Figure 1

MAINTENANCE



WARNING: UNPLUG THE UNIT BEFORE ATTEMPTING TO SERVICE OR REMOVE ANY COMPONENT!

CAUTION: This unit is permanently lubricated. Oiling is not required. Do not open the sealed portion of the unit or remove housing screws.

Periodic cleaning of the pump parts will prolong the life and efficiency of the pump. Refer to Fig. 2 for the assembly and disassembly of the pumping head.



1. Lightly clean any corrosion or debris that may clog the impeller. Use a brush and penetrating oil and lightly scrape. NOTE: Do not allow sediment from parts being washed to build up and restrict the flow of fluid into the pump.
2. Turn the impeller by hand to make sure it is free. If it does not turn or if pump is tripping circuit breaker, or not operating properly after cleaning, return to an authorized Little Giant service center. Do not attempt repairs yourself. If it does turn, replace volute and re-install into parts washer.
3. Be certain power cord is protected from solvent and has no nicks or cuts.

Do not remove housing screws. Will void warranty.

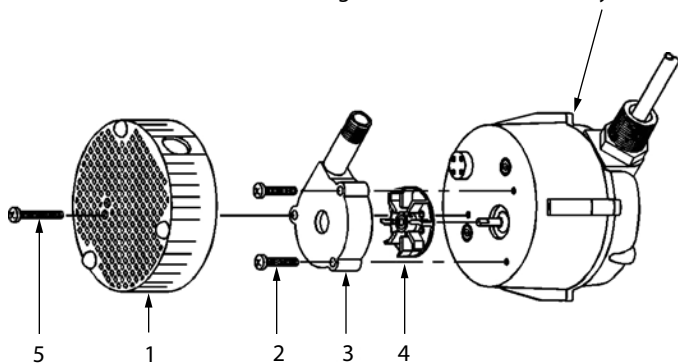

Figure 2

TROUBLESHOOTING



CAUTION: Do not open the sealed portion of the unit or remove the housing screws.

1. Should the unit fail to operate, check the following:
 - a. Power supply and connections
 - b. Is the pump below liquid level?
 - c. Is air trapped in the pump head?
 - d. Is there sediment build-up over pump inlet?
2. An air lock or bubble will prevent the unit from pumping. Trapped air can usually be removed by turning the pump off and restarting. Ensure that the discharge line is sloping upward to prevent formation of air pockets.
3. If these operations do not restore the unit to full service, call your dealer or service technician.

REPLACEMENT PARTS

ITEM	PART NO.	DESCRIPTION	QTY.
1	101903	Screen	1
2	902411	Screw, 8-18 X 1"	2
3	101351	Volute	1
4	101433	Impeller assembly	1
5	902408	Screw, #8 self-tapping	1

LIMITED WARRANTY

THIS WARRANTY SETS FORTH THE COMPANY'S SOLE OBLIGATION AND PURCHASER'S EXCLUSIVE REMEDY FOR DEFECTIVE PRODUCT.

Franklin Electric Company, Inc. and its subsidiaries (hereafter "the Company") warrants that the products accompanied by this warranty are free from defects in materials or workmanship of the Company that exist at the time of sale by the Company and which occur or exist within the applicable warranty period. Any distributor, sub-distributor, recipient, end-user and/or consumer agrees that by accepting the receipt of the products, the distributor, sub-distributor, recipient, end user and/or consumer expressly agrees to be bound by the terms of the warranty set forth herein.

I. Applicable Warranty Period

The products accompanied by this warranty shall be covered by this Limited Warranty for a period of 12 months from the date of original purchase by the consumer. In the absence of suitable proof of purchase date, the warranty period of this product will begin to run on the product's date of manufacture.

II. Instructions Applicable to this Limited Warranty

1. Consumers wishing to submit a warranty claim must return the products accompanied by this warranty to the point of purchase for warranty consideration.
2. Upon discovery of a defect, any personal injury, property damage or any other type of resulting damage, if applicable, shall be reasonably mitigated to the extent possible.
3. At its discretion, the Company may inspect products either at its facilities, or in the field, and after determination of a warranty claim, will, at its option, repair or replace defective parts. Repaired or replaced parts will be returned freight prepaid by the Company.
4. This warranty policy does not cover any labor or shipping charges. The Company shall not be liable for any costs or charges attributable to any product testing, maintenance, installation, repair or removal, or for any tools, supplies, or equipment needed to install, repair, or remove any product.

III. Limitations Applicable to this Limited Warranty

THIS WARRANTY DOES NOT APPLY TO ANY OF THE FOLLOWING:

1. Brushes, impeller or cam on models with brush-type motors and/or flex-vane impellers.
2. Any product that is not installed, applied, maintained and used in accordance with the Company's published instructions, applicable codes, applicable ordinances and/or with generally accepted industry standards.
3. Any product that has been subject to misuse, misapplication, neglect, alteration, accident, abuse, tampering, acts of God (including lightning), acts of terrorism, acts of war, fire, improper storage or installation, improper use, improper maintenance or repair, damage or casualty, or to an excess of the recommended maximums as set forth in the product instructions.
4. Any product that is operated with any accessory, equipment, component, or part not specifically approved by the Company.
5. Use of replacement parts not sold by the Company, the unauthorized addition of non-Company products to other Company products, and the unauthorized alteration of Company products.
6. Products damaged by normal wear and tear, normal maintenance services and the parts used in connection with such service, or any other conditions beyond the control of the Company.
7. Any product that has been used for purposes other than those for which it was designed and manufactured.

8. Any use of the product where installation instructions and/or instructions for use were not followed.
9. Products connected to voltage other than indicated on nameplate.
10. Products where the pump was exposed to any of the following: sand, gravel, cement, grease, plaster, mud, tar, hydrocarbons, hydrocarbon derivatives (oil, gasoline, solvents, etc.) or other abrasive or corrosive substances.
11. Products in which the pump has been used to pump or circulate anything other than fresh water at room temperature.
12. Products in which the pump was allowed to operate dry (fluid supply cut off).
13. Products in which the sealed motor housing has been opened or the product has been otherwise dismantled by customer.
14. Products in which the cord has been cut to a length of less than three feet.

The Company reserves the right at any time, and from time to time, to make changes in the design and/or improvements upon its product without thereby imposing any obligation upon itself to make corresponding changes or improvements in or upon its products already manufactured and/or previously sold. The Company further reserves the right to substitute parts or components of substantially equal quality in any warranty service required by operation of this Limited Warranty.

This written Limited Warranty is the entire warranty authorized and offered by the Company. There are no warranties or representations beyond those expressed in this document.

THIS WARRANTY AND REMEDY IS IN LIEU OF ALL OTHER WARRANTIES AND REMEDIES INCLUDING WITHOUT LIMITATION, WARRANTIES OF MERCHANTABILITY AND/OR FITNESS FOR A PARTICULAR PURPOSE, WHICH ARE HEREBY SPECIFICALLY DISCLAIMED AND EXPRESSLY EXCLUDED. CORRECTION OF NON-CONFORMITIES, IN THE MANNER AND FOR THE PERIOD OF TIME AS SET FORTH ABOVE, SHALL CONSTITUTE FULFILLMENT OF ALL LIABILITY OF THE COMPANY TO THE PURCHASER WHETHER BASED ON CONTRACT, NEGLIGENCE, OR OTHERWISE.

THE COMPANY SHALL NOT BE LIABLE FOR INCIDENTAL, CONSEQUENTIAL OR SPECIAL DAMAGES SUCH AS, BUT NOT LIMITED TO:

DAMAGE TO OR LOSS OF OTHER PROPERTY OR EQUIPMENT, LOSS OF USE OF EQUIPMENT, FACILITIES OR SERVICE, LOSS OF PROFIT OR SALES, COST OF PURCHASES OR REPLACEMENT GOODS, CLAIMS OF CUSTOMERS OF THE PURCHASER, FAILURE TO WARN AND/OR INSTRUCT, LOSS OF OTHER PRODUCTS, OR COSTS OF ENVIRONMENTAL REMEDIATION, OR DIMINUTION IN PROPERTY VALUE. THE REMEDIES OF THE PURCHASER SET FORTH HEREIN ARE EXCLUSIVE, AND THE LIABILITY OF THE COMPANY SHALL NOT, EXCEPT AS EXPRESSLY PROVIDED HEREIN, EXCEED THE PRICE OF THE PRODUCTS UPON WHICH SUCH LIABILITY IS BASED. DAMAGES AS SET FORTH IN THIS PARAGRAPH SHALL BE REASONABLY MITIGATED TO THE EXTENT POSSIBLE. THIS PARAGRAPH SHALL ALSO APPLY TO ALL DAMAGES RESULTING FROM CONDITIONS SET FORTH IN SECTION III ABOVE AND (1) DEFECTS IN PRODUCT PROTOTYPES OR REPLACEMENT PART PROTOTYPES THAT HAVE NOT BEEN PUT INTO PRODUCTION, CIRCULATED AND SOLD BY THE COMPANY, AND/OR (2) DEFECTS THAT WERE NOT FOUND AT THE TIME OF SALE DUE TO SCIENTIFIC AND TECHNOLOGICAL REASONS.

This Limited Warranty gives you specific legal rights. You may have other rights, which vary according to the applicable laws and regulations. Where any term of this warranty is prohibited by such laws, it shall be null and void, but the remainder of this warranty shall remain in full force and effect.

DISCLAIMER: Any oral statements about the product made by the seller, the Company, the representatives or any other parties, do not constitute warranties, shall not be relied upon by the user, and are not part of the contract for sale. Seller's and the Company's only obligation, and buyer's only remedy, shall be the replacement and/or repair by the Company of the product as described above. Before using, the user shall determine the suitability of the product for his intended use, and user assumes all risk and liability whatsoever in connection therewith.

For technical assistance, please contact 800.701.7894

**www.franklinwater.com
CustomerService@lgpc.com**
