

4E-34NR SERIES - 1/12 HP

APPLICATIONS

Small submersible oil-filled pump with epoxy coated cast aluminum housing. For commercial, industrial and home applications including statuary fountains, water displays, air conditioners, machine tool coolants, and many other applications where liquid must be transferred or recirculated.

FEATURES

- Epoxy coated die-cast aluminum housing
- Oil-filled motor
- 24.5-foot maximum lift
- Screened inlet
- 1/2-inch MNPT discharge
- Thermal overload protection
- For submersible use only



4E-34NR



SERIES SPECIFICATIONS

Item No.	Model	Discharge	Intake	Listing(s)	HP	Volts	Hz	Amps	Watts	Gallons per hour (Liter per hour) @ Height					Shut-Off	PSI	Cord	Weight lbs (Kg)
										1'	3'	5'	10'	20'				
504203	4E-34NR	1/2" MNPT	3/4" FNPT	UL	1/12	115	60	3.5	210	810 (3066)	790 (2990)	745 (2820)	613 (2320)	173 (655)	24.5' (7.5 m)	10.6	6' (1.8 m)	8.5 (3.86 Kg)
504216	4E-34NRY	1/2" MNPT	3/4" FNPT	UR	1/12	230	50/60	1.7	210	810 (3066)	790 (2990)	745 (2820)	613 (2320)	173 (655)	24.5' (7.5 m)	10.6	12' (3.7 m)	8.5 (3.86 Kg)

SMALL SUBMERSIBLE PUMPS

4E-34NR SERIES - 1/12 HP

ENGINEERING DATA

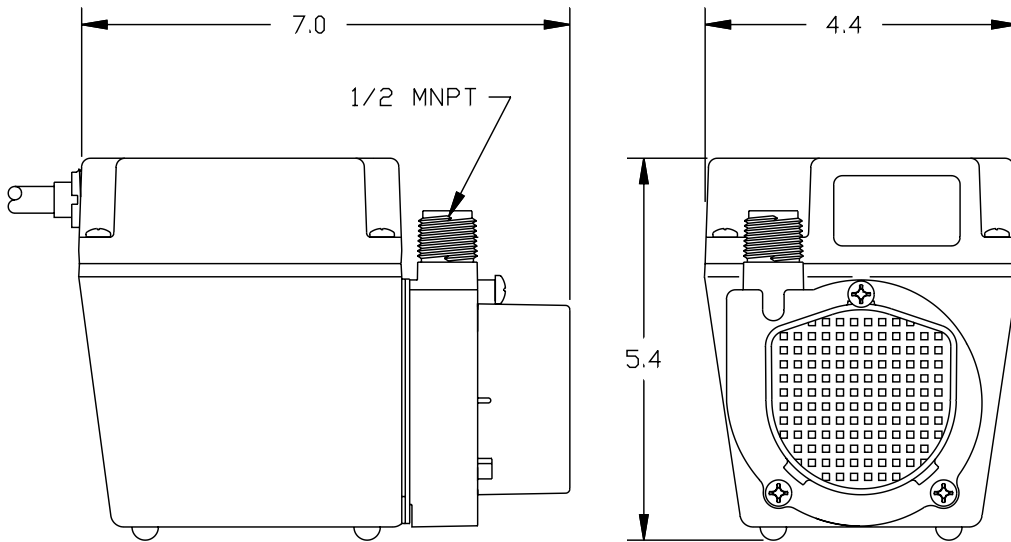

PERFORMANCE DATA

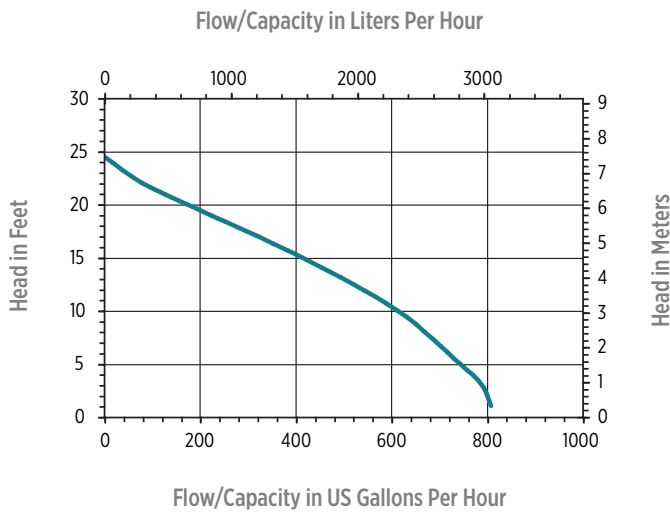

REPLACEMENT PARTS

Volute	103334
Impeller	104435
Screen	102909
Gasket	103601

