

## NK-1 SERIES - 1/150 HP

### APPLICATIONS

For commercial, industrial, and home use worldwide, where liquid must be transferred or recirculated, Little Giant's NK-1 Series is the solution. Applications include aquariums, swimming pools, water displays, ice makers, air conditioners, boat bailing, fuel oil transfer, circulating water for welding and pipe threading machines, pumping mild chemicals such as soap solutions, acids, plating solutions, and fertilizers.

### FEATURES

- Corrosion resistant nylon body
- Oil-filled motor
- 10.2-foot maximum lift
- Screened inlet
- 1/4-inch MNPT discharge
- Thermal overload protection
- For submersible use only



NK-1



### SERIES SPECIFICATIONS

Item No.	Model	Discharge	HP	Volts	Hz	Amps	Watts	Gallons per hour (Liter per hour) @ Height			Shut-Off	PSI	Cord	Weight lbs (Kg)
								1'	3'	5'				
526003	NK-1	1/4" MNPT	1/150	115	60	1.1	70	210 (795)	180 (681)	150 (568)	10.2' (3.1 m)	4.4	6' (1.8 m)	3.67 (1.66 Kg)

# SMALL SUBMERSIBLE PUMPS

## NK-1 SERIES - 1/150 HP

### ENGINEERING DATA

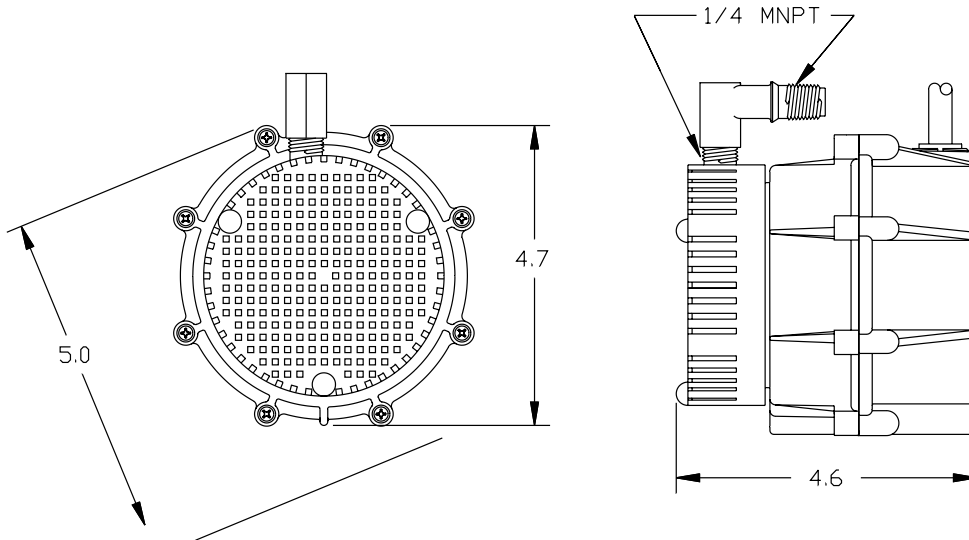

### PERFORMANCE DATA

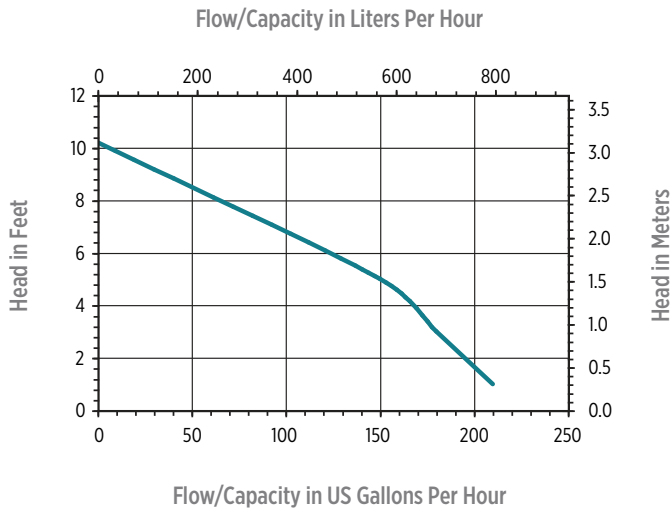

### REPLACEMENT PARTS

<b>Volute</b>	116375
<b>Impeller</b>	116437
<b>Screen</b>	101376
<b>Seal Ring</b>	928007
<b>Backplate</b>	126377
<b>Elbow</b>	943076

